



**Catalogue**  
FOOD SERVICE  
**Chapter**  
COOKING

**Specific model**  
B-E705 I 400V 3N

19074788

04/09/2023

**DENOMINATION:**

Electric grill, stainless steel grill, half module, 700 range.

**DESCRIPTION :**

- Stamped surface tops manufactured in 1.5 mm thick AISI-304 stainless steel
- Laser-cut joints and automatic welding. Hidden screws.
- Fitted with an opening to collect cooking grease and a tray to store it.
- Machines are fitted with removable 130 mm high guards to prevent splashes, made of stainless steel.
- High temperature enamelled cast iron flue protector.
- Access to the components from the front.
- Machines with IPX5 grade water protection.
- Groups of stainless steel covered elements upon which you can cook food directly (a group of 3 elements for half-sized module models and 2 groups for whole module models).
- Water tray for safety. It also allows an adequate level of humidity to be reached for optimum cooking conditions.

**POSSIBLE OPTIONS :**

- 230 1N- Transformation A 230 V single phase
- 230 III - A 230 V three-phase transformation without neutral
- MARINE - Other machines - Ship transformation - 440 III

**POSSIBLE ACCESSORIES :**

- ACCESSORIES KORE
- STANDS 700
- TALL CHIMNEY KORE

**DIMENSIONS**



X Width	400 mm	X Gross width	440 mm
Y Depth	730 mm	Y Gross depth	822 mm
Z Height	290 mm	Z Gross height	535 mm
Net Weight	30,0 kg	Gross Weight	43,0 kg
Net volume	0,080 m3	Gross volume	0,193 m3

**ELECTRICITY TECHNICAL SPECIFICATIONS**

Electric power	4,080 kW
Amperage (A)	5,9A
Heating power	4,08 kW
Voltage	400V - 3N
Electric frequency	50/60Hz

**CONNECTIONS TECHNICAL SPECIFICATIONS**

230 V three-phase wiring	3X1,5MM2+T - 16A
Single-phase 230V wiring	2X2,5MM2+T - 25A
Three-phase +N 400V wiring	3X1,5MM2+T+N - 10A



**Catalogue**  
FOOD SERVICE  
**Chapter**  
COOKING

**Specific model**  
B-E705 | 400V 3N

19074788

04/09/2023

## B-E705

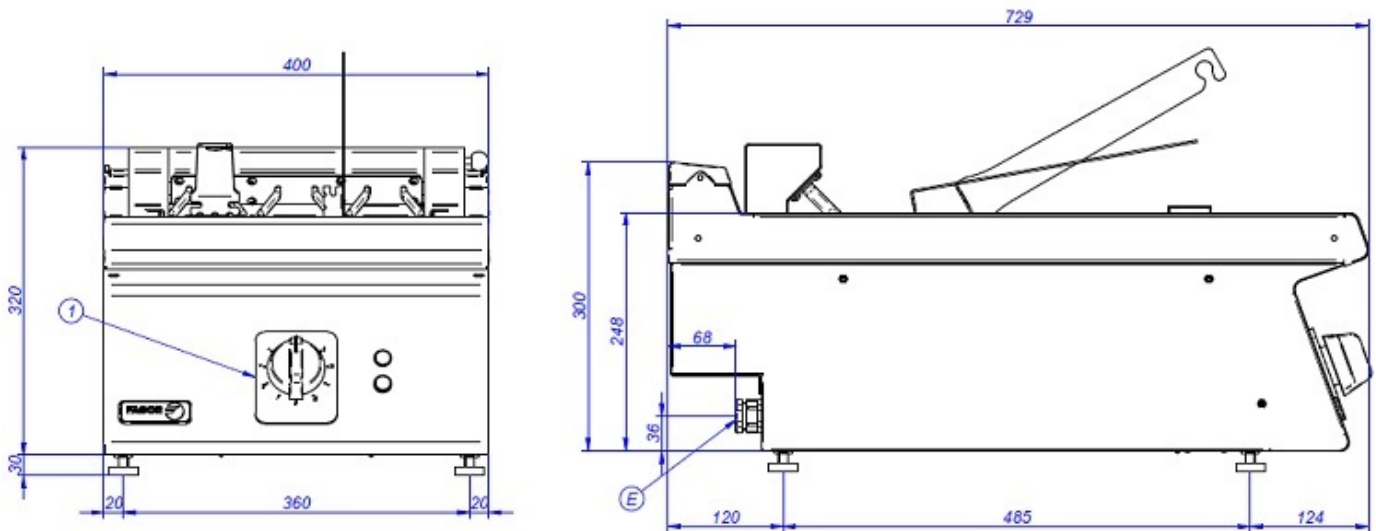

1 - Mando eléctrico  
2 - Conexión eléctrica

Electric control  
Electrical connection



**Catalogue**  
FOOD SERVICE  
**Chapter**  
COOKING

**Specific model**  
MB-705

19057229

04/09/2023

**DENOMINATION:**

Stand, half module, 700 range.

**DESCRIPTION :**

- "- Manufactured with a solid structure in AISI-304 stainless steel.
- Hidden screws.
- Can be quickly connected to serve as a support for surface top elements from the KORE 700 range.
- "
- "- Can be used as an open storage element.
- Designed to be attached to optional kits: doors ."

**POSSIBLE ACCESSORIES :**

- ACCESSORIES KORE
- KORE WHEELS

**DIMENSIONS**

X Width	400 mm	X Gross width	440 mm
Y Depth	556 mm	Y Gross depth	822 mm
Z Height	600 mm	Z Gross height	750 mm
Net Weight	39,0 kg	Gross Weight	45,0 kg
Net volume	0,160 m3	Gross volume	0,271 m3

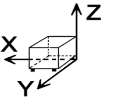



**Catalogue**  
FOOD SERVICE  
**Chapter**  
COOKING

**Specific model**  
MB-705

19057229

04/09/2023

