

Vues Standard
Echelle 1:3

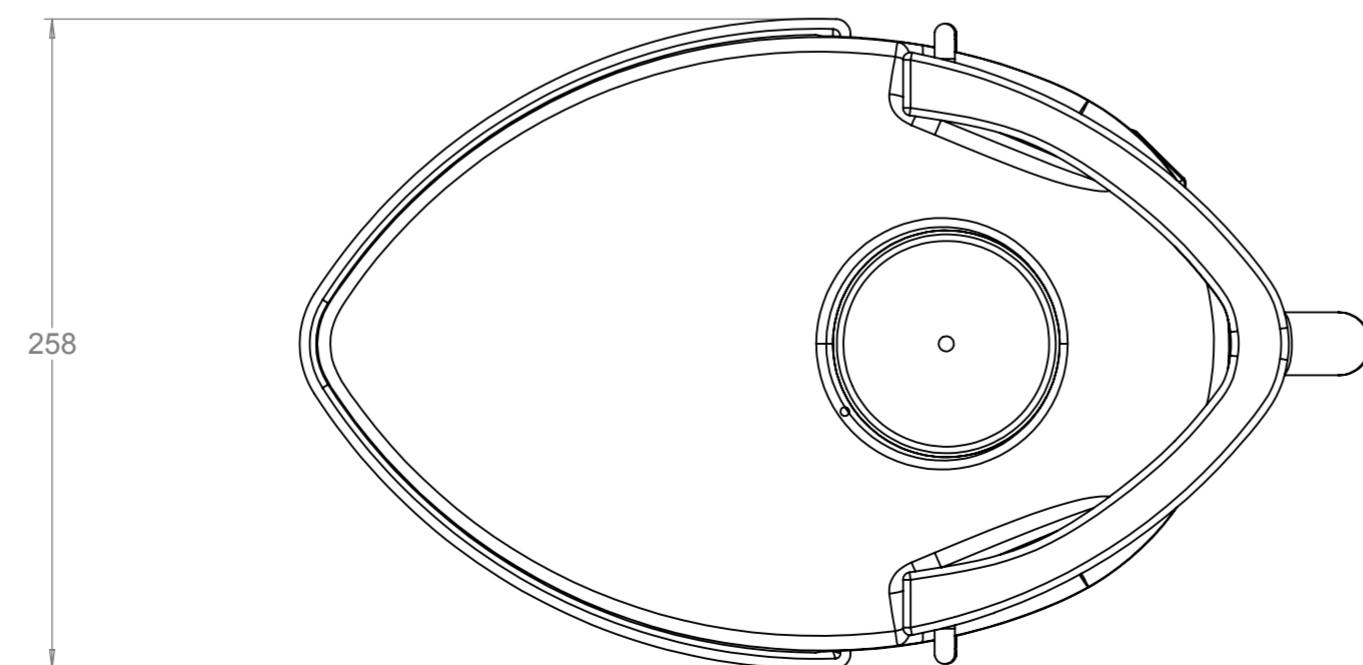

Longueur du câble d'alimentation : 2m

Débattement nécessaire
Echelle 1:6

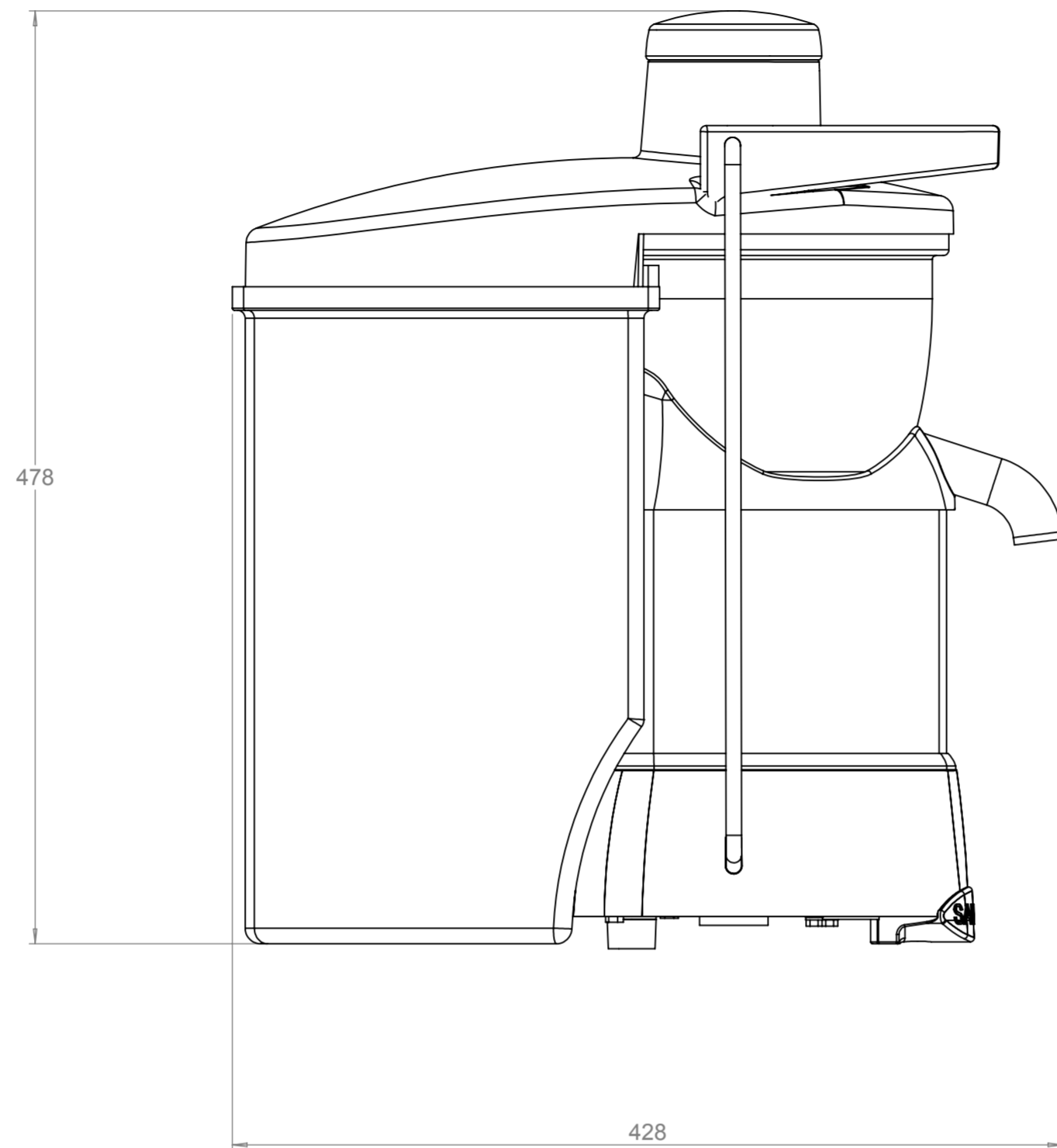
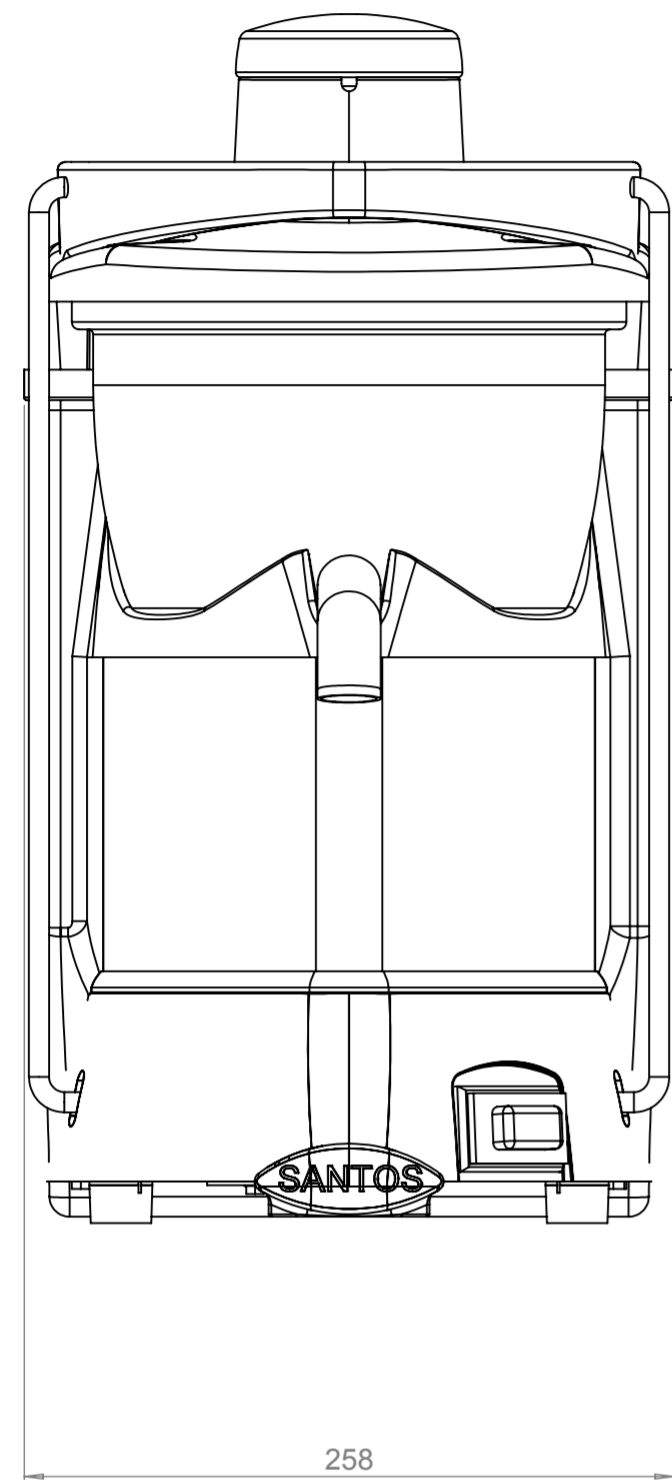
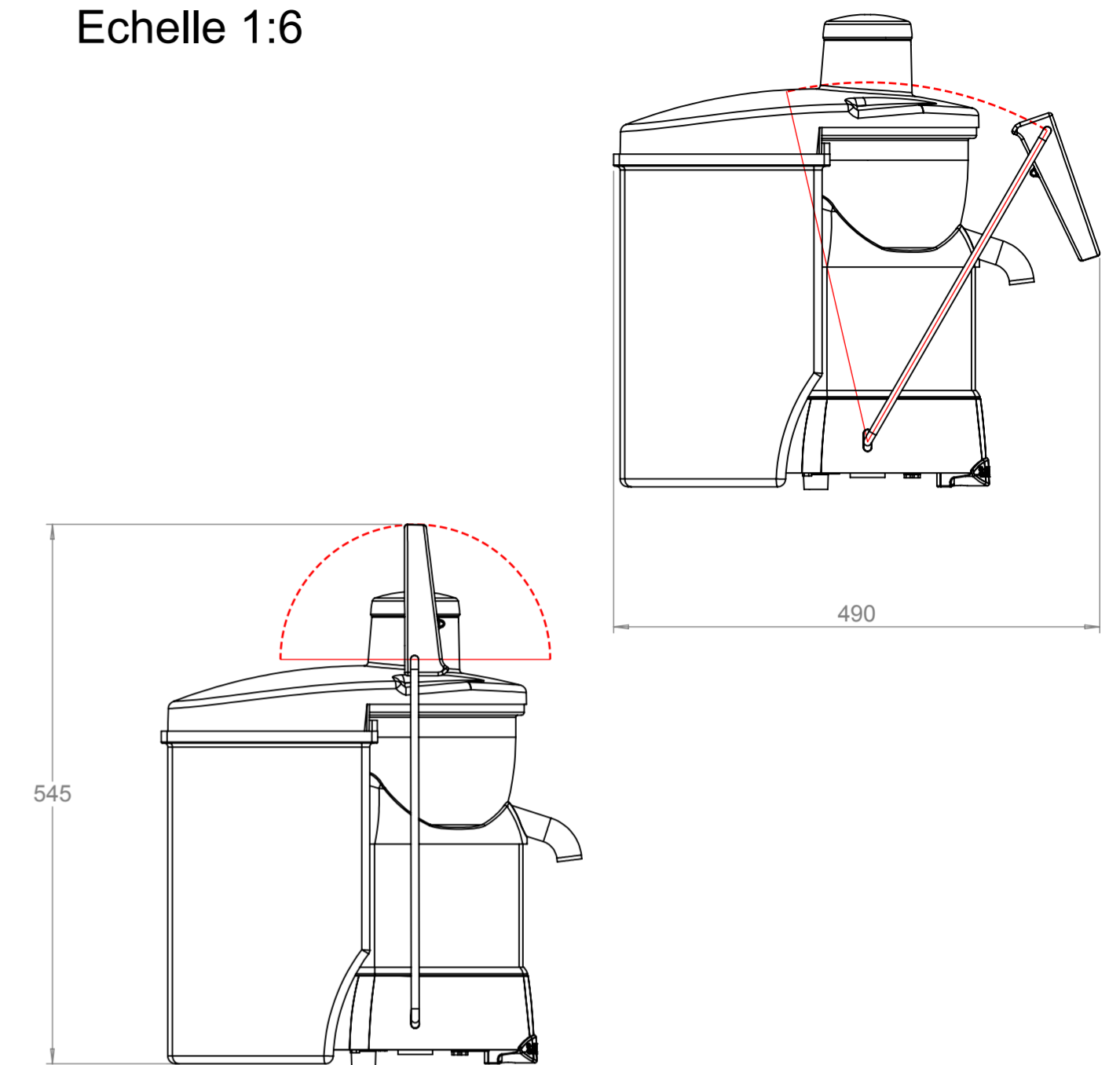

Vue 3D
Echelle 1:5

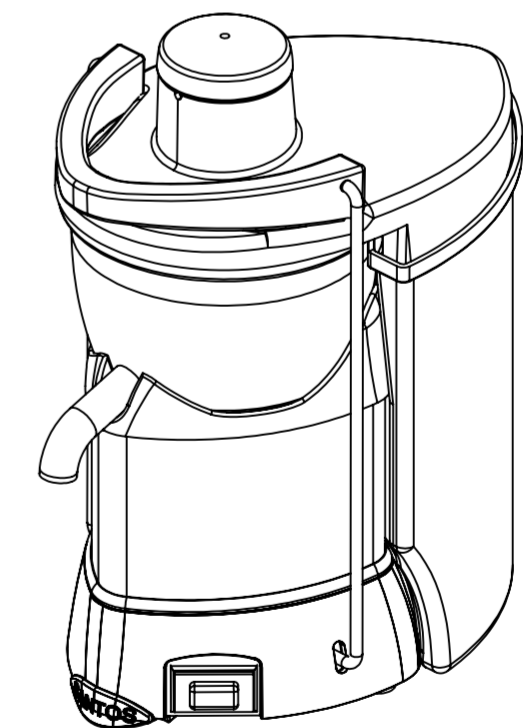

PLAN D'INSTALLATION

Tolérances générales ± 2  02/06/2005

Désignation :

N°50 Centrifugeuse

Reproduction et utilisation interdites sans accord écrit de la société SANTOS
140, 150 avenue Roger SALENGRO 69120 Vaulx en Velin Fax 04 78 26 58 21

MODIFICATIONS

Ind. A

