



Catalogue
FOOD SERVICE
Chapter
COOKING

Specific model
C-I745 400V 3~

19057293

04/09/2023

DENOMINATION:

Induction cooker, 1 module, 700 range.

DESCRIPTION :

- 6 mm thick vitro ceramic glass, hermetically sealed in the 1.5 mm thick AISI-304 stainless steel surface top.
- Laser-cut joints and automatic welding. Hidden screws.
- Perfect control of cooking thanks to the energy regulator with 10 power levels which makes it possible to work at low temperatures for delicate recipes or at the highest temperature for quick service.
- Energy is only transferred to the area below the container and the rest of the vitro ceramic surface remains cold.
- It operates when it detects the presence of the container. When the container is removed, it stops heating.
- Consequently, it provides considerable energy savings (energy use is reduced by around 50% compared to gas burners).
- The working environment and atmosphere are more comfortable since the energy is concentrated at the base of the pan, heat radiation and dispersal are reduced and the cooking temperature is reached quickly.
- Safety against overheating. Error messages shown through flashing lights.
- High-temperature enamelled cast iron flue protector.
- Access to components from the front.
- Machines with IPX5 grade water protection."
- Cooking areas demarcated by a circular Ø 260 mm screen print, with 5 kW power in each area, quick heating and ideal for à la carte service.

POSSIBLE ACCESSORIES :

- ACCESSORIES KORE
- STANDS 700
- TALL CHIMNEY KORE

DIMENSIONS



X Width	800 mm	X Gross width	840 mm
Y Depth	730 mm	Y Gross depth	822 mm
Z Height	290 mm	Z Gross height	535 mm
Net Weight	85,0 kg	Gross Weight	103,0 kg
Net volume	0,170 m3	Gross volume	0,369 m3

ELECTRICITY TECHNICAL SPECIFICATIONS

Electric power	22,200 kW
Amperage (A)	32A
Heating power	20,00 kW
Voltage	400V - 3~
Electric frequency	50/60Hz

CONNECTIONS TECHNICAL SPECIFICATIONS

Three-phase +N 400V wiring	3X6MM2+T+N
----------------------------	------------



Catalogue
FOOD SERVICE
Chapter
COOKING

Specific model
C-I745 400V 3~

19057293

04/09/2023

C-I725

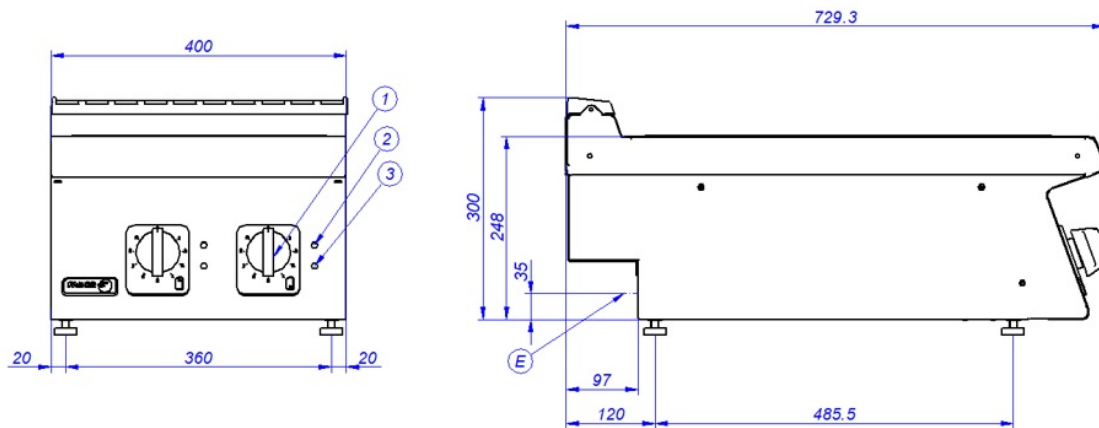

C-I745

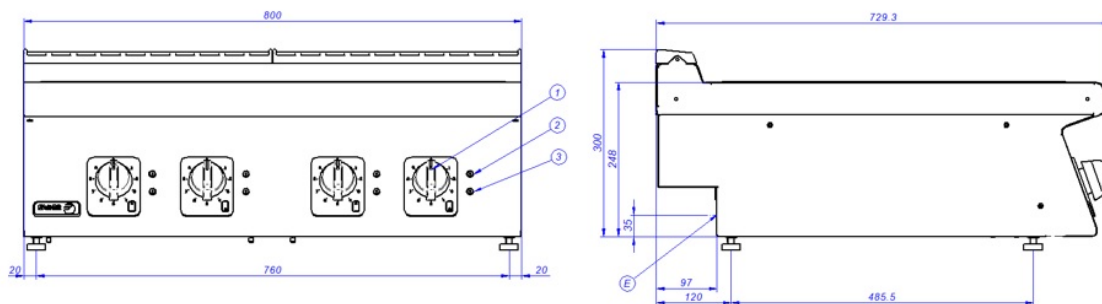

E – Conexión eléctrica
1 – Mando eléctrico
2 – Piloto verde
3 – Piloto ámbar

Electrical connection
Electric control
Green pilot
Ambar pilot

Connexion électrique
Commande électrique
Lumière verte
Lumière ambre



Catalogue
FOOD SERVICE
Chapter
COOKING

Specific model
MB-710

19057290

04/09/2023

DENOMINATION:

Stand, 1 module, 700 range.

DESCRIPTION :

- "- Manufactured with a solid structure in AISI-304 stainless steel.
- Hidden screws.
- Can be quickly connected to serve as a support for surface top elements from the KORE 700 range.
- "
- "- Can be used as an open storage element.
- Designed to be attached to optional kits: doors ."

POSSIBLE ACCESSORIES :

- ACCESSORIES KORE
- KORE WHEELS

DIMENSIONS

X Width	800 mm	X Gross width	840 mm
Y Depth	556 mm	Y Gross depth	822 mm
Z Height	600 mm	Z Gross height	750 mm
Net Weight	39,0 kg	Gross Weight	45,0 kg
Net volume	0,330 m3	Gross volume	0,518 m3

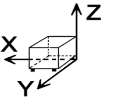



Catalogue
FOOD SERVICE
Chapter
COOKING

Specific model
MB-710

19057290

04/09/2023

